

S1/S2
Series
III

CRAFT BEARING

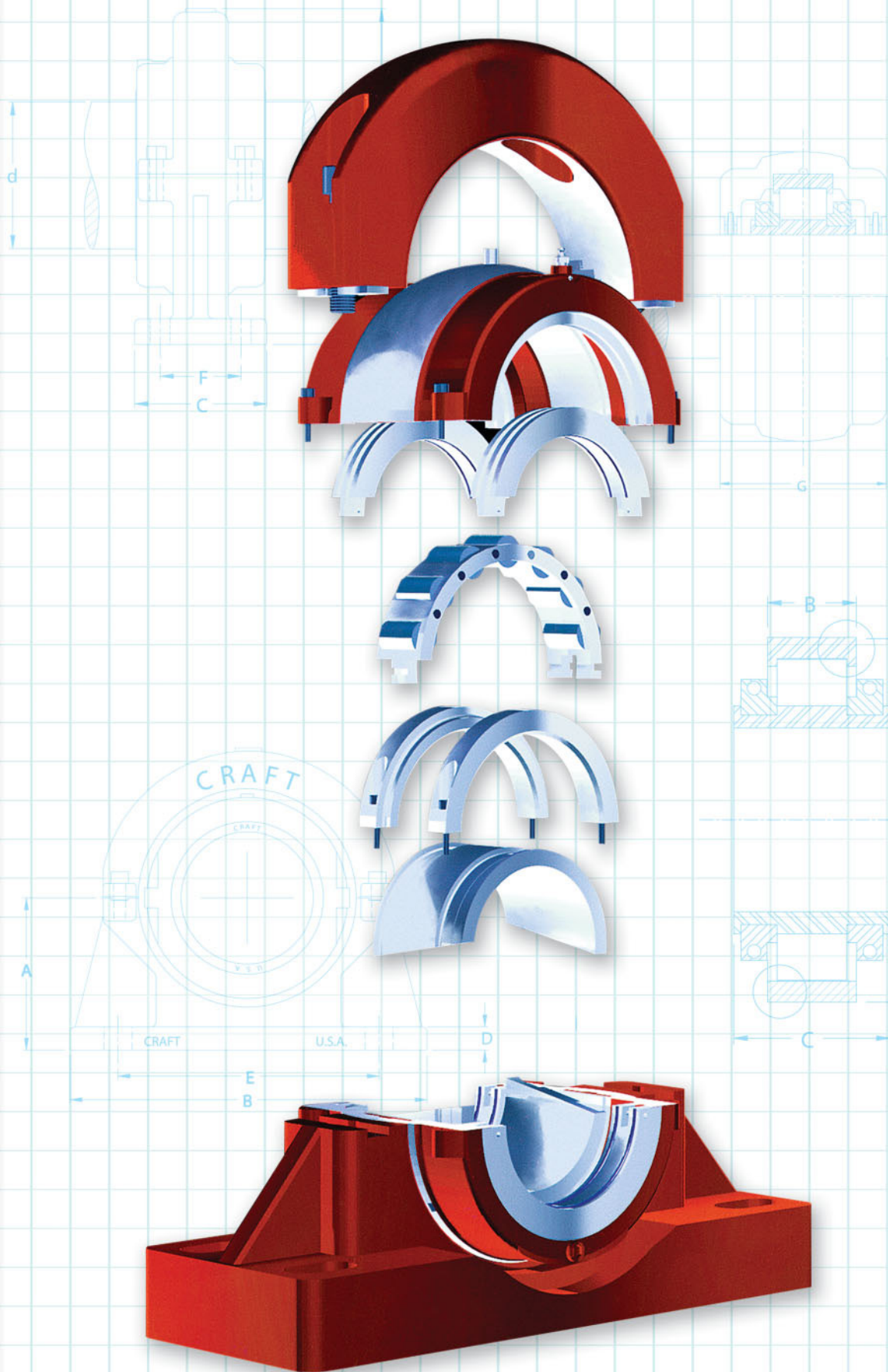

CRAFT
Bearing Company, Inc.

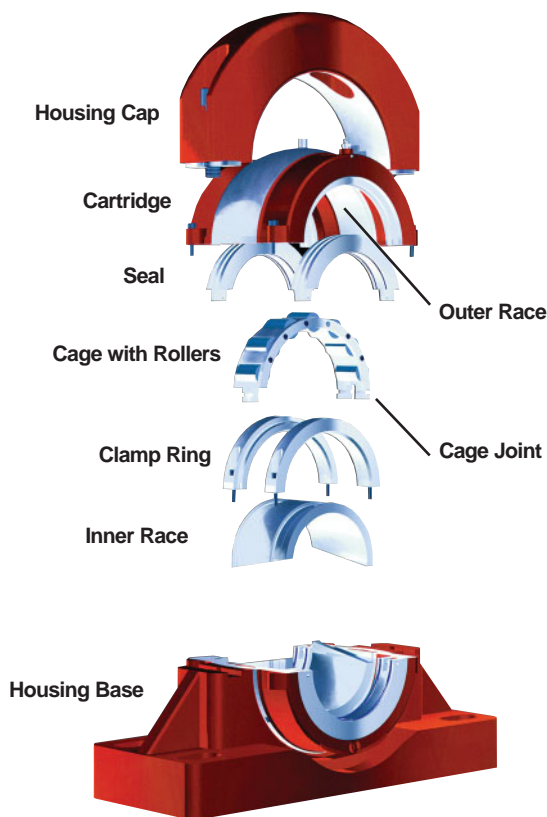

CARTRIDGE ASSEMBLY

The Craft Cartridge Assembly consists of the following component parts:

- Either the Float or Held Bearing (as the application requires)
- Aluminum triple labyrinth-ATL-seals (standard, other seals available upon request)
- The Cartridge itself, made from high-quality ductile iron

The outside diameter of the cartridge is spherically machined to accommodate initial shaft misalignment. This allows the Bearing and Cartridge Assembly to align externally. The seal remains on a parallel axis with the shaft, maintaining a 100% seal along the shaft.

All bearing outer races are positioned in the cartridge by side pusher screws. This allows the proper positioning of the outer races in the cartridge. The side pusher screws must be backed off before attempting to remove outer races.

The Craft Cartridge Assembly may be purchased separately for replacement in a Craft Housing or other appropriate mounting fixtures.

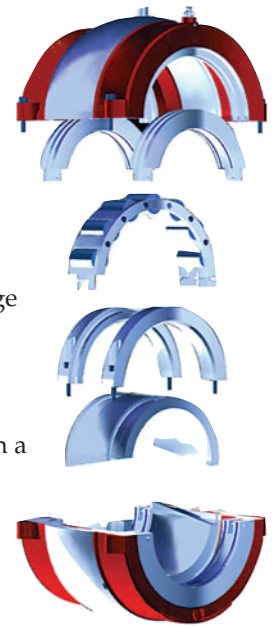

THE SPLIT BEARING

Craft Bearing Company manufactures Split Cylindrical Roller Bearings which combine all the advantages of conventional anti-friction roller bearings with the added feature of being easily assembled around a shaft. The complete assembly is engineered in halves to ease installation, inspection, and /or replacement of pillow block bearings without removing or disrupting other elements of the system. **The Split makes the difference!** The Craft Bearing and all its component parts are manufactured in the United States.

PILLOW BLOCK

The Craft Pillow Block consists of the Cartridge Assembly (with either a Float or Held Bearing) and the Housing Assembly, which is made of quality ductile iron. The inside diameter of the housing is spherically machined to accept the Cartridge Assembly. The base to center height of the Pillow Block meets and in some cases is less than the industry standard. In cases where shim stock is used to increase the base to center height needed for a given application, it is imperative that the housing base be completely supported.

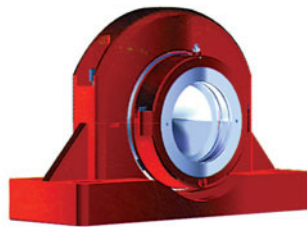

NOTE All hardware used in the assembly of the Craft Pillow Block is of the American standard type, not metric.

Bearings, cartridges, and housings of the same series and grouping are interchangeable with each other. However, their integral parts are not.

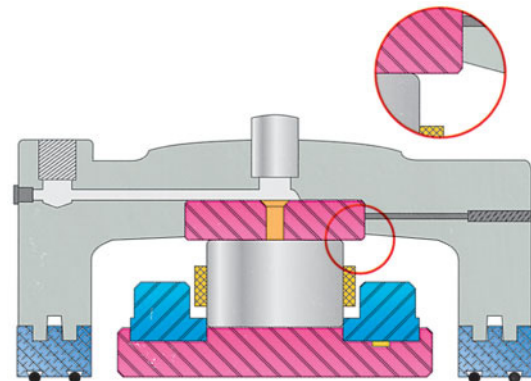

FLOAT BEARING (Non-locating)

The Craft Float Bearing (FL suffix) allows unrestricted axial movement, either expansion or contraction. The roller assembly is held in place by the flanges of the inner race clamping collars, while allowing the roller cage assembly to locate itself, or float, across the face of the outer race. As a result, the roller does not sustain axial forces while retaining full radial load carrying capacities.

CRAFT
Bearing Company, Inc.

5000 Chestnut Avenue • Newport News, Virginia 23605

phone 757-247-6000 • fax 757-247-6300

e-mail info@craftbearing.com

website www.craftbearing.com

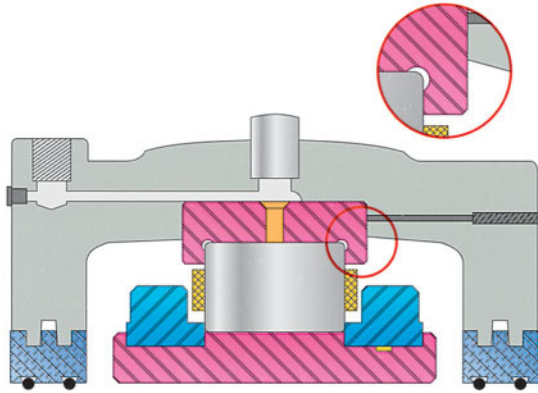

HELD BEARING (LOCATING)

The Craft Held Bearing (HD suffix) is installed as a fixed bearing to locate the shaft and direct shaft expansion in either axial direction. The flanges of the clamping collars and the shoulders of the outer race form a guide path which contain the rollers, eliminating axial float while accommodating thrust. The Held Bearing handles axial loading virtually independent of the radial load. Only one Held Bearing should be applied to a single shaft segment. The other support bearings should be Float Bearings.

MATERIALS

Materials used in Craft Pillow Block Bearings meet or exceed the standards set by the American Bearing Manufacturers Association (ABMA). The rolling elements and parts forming the running surfaces of the bearing are made of SAE 52100 high carbon chromium steel, through hardened, to give optimum fatigue life and dimensional stability. The cartridge and housing are made of cast ductile iron, for higher tensile strength and elasticity, and substantially more ductility over conventional cast iron.

BEARING LOAD RATINGS AND LIFE

All calculations to determine the load carrying capacities of the Craft Bearing are based on and in accordance with ABMA and International Organization for Standardization (ISO) standards.

Basic Rating Life

L₁₀, or Basic Rating Life, is defined by the ISO formula, $L_{10} = (C_R/P_R)^p$, where:

L₁₀ = Basic Rating Life, in millions of revolutions

C_R = Basic Dynamic Load Rating

P_R = Dynamic Equivalent Radial Load

p = Exponent of the Life Equation 10/3

L₁₀ is the minimum expected life for 90% of a group of like bearings. Median life, which 50% of the group will complete or exceed, is approximately five times the rating life.

CUSTOM WORK

Stainless steel cartridges and housings and special application bearings are available upon request. Please contact our Engineering Department.

BEARING LUBRICATION

The primary purpose of lubrication is to establish a load carrying film on the component parts of the bearing so that metal to metal contact is avoided between the rolling elements. Lubrication also acts as an inhibitor to corrosion and assists in the sealing process. Appropriate lubrication selection must be based on the critical criteria (speeds, loads, temperatures, etc.) of the bearing application.

Grease Lubrication

Grease of a #2 consistency with an EP (extreme pressure) additive is the preferred lubricant in most normal applications. All Craft Cartridges have a grease fitting, allowing the lubricant direct access to the rolling surfaces of the bearing. Depending on the application, excessive grease will result in an abnormal rise in bearing temperature. Therefore, Craft Cartridges are also supplied with purging capabilities. This is done by removing the purge plug, located in the lower half of the cartridge, and allowing the grease to seek its own level. Once this is accomplished, the plug is then replaced.

Greasing Capacities

All bearing component parts should be cleaned and free of preservatives and contaminants. As the component parts of the bearing are assembled around the shaft, they should be hand coated with grease. The bearing should never be assembled dry and the lubricant injected after the unit is mounted. As a general guide, grease should be applied based on the following chart.

dn (RPM x Shaft Size)	Percentage of Packing (See chart, Grease Capacity)
0 to 2000	100%
2000 to 4000	75%
4000 to 6000	50%
6000 to 8000	33%
8000 and up	25%

Greasing Schedules

Held Bearing (Locating) Due to the cycloidal action of the rollers against the flanges of the clamping collars and the shoulders of the outer raceway, the Held Bearing requires a more frequent lubrication schedule than the Float Bearing. Every 250 operating hours, or at two-week intervals, the bearing should get three to four shots of grease (½ oz.), with a suggested yearly thorough cleaning and re-lubrication.

Float Bearing (Non-locating) Every 500 hours, or at one month intervals, the bearing should get three to four shots of grease, with a suggested yearly thorough cleaning and re-lubrication.

The above greasing schedule is for reference only, and may be modified to accommodate the application. Experience will determine the best interval for each application.

Oil Lubrication

Oil lubrication may be required in applications where extreme speed, high axial load, temperature, and/or other operating conditions may be factors. To insure proper selection and utilization of oil lubrication, please contact Craft Bearing's Engineering Department.

NOTE Axial capacity and maximum RPM may be reduced when extreme pressure grease or oil lubrication is not used.

S1 SERIES SMALL BORE

MOUNTED UNIT													
Shaft Diameter	Complete* Component	Pedestal Housing	A **	B	C †	D	E		F	H	Bolts	Weight lbs.	
							Minimum	Maximum					
1 7/16 1 1/2 40mm	S1 BCH 107 S1 BCH 108 S1 BCH 40mm	PH 1	2 3/8	9	2 3/8	7/8	6 3/4	7 1/2	—	5 1/2	Two 1/2	11.05	
1 11/16 1 3/4 1 15/16 2 45mm 50mm	S1 BCH 111 S1 BCH 112 S1 BCH 115 S1 BCH 200 S1 BCH 45mm S1 BCH 50mm	PH 2	2 3/4	10 5/8	2 3/8	1	8	8 7/8	—	6 1/4	Two 5/8	18.5	
2 3/16 2 1/4 2 7/16 2 1/2 60mm 65mm	S1 BCH 203 S1 BCH 204 S1 BCH 207 S1 BCH 208 S1 BCH 60mm S1 BCH 65mm	PH 3	3 5/32	11	2 3/4	1 1/4	8 7/8	9 1/2	—	7	Two 5/8	25.4	
2 11/16 2 3/4 2 15/16 3 70mm 75mm	S1 BCH 211 S1 BCH 212 S1 BCH 215 S1 BCH 300 S1 BCH 70mm S1 BCH 75mm	PH 4	3 3/4	13	3	1 1/2	10 1/4	11	—	7 15/16	Two 3/4	33	
3 3/16 3 1/4 3 7/16 3 1/2 80mm 85mm 90mm	S1 BCH 303 S1 BCH 304 S1 BCH 307 S1 BCH 308 S1 BCH 80mm S1 BCH 85mm S1 BCH 90mm	PH 5	4 13/32	15	5 1/2	1 3/4	12 7/16	13 3/8	3 1/2	10	Four 3/4	64.3	
3 11/16 3 3/4 3 15/16 4 100mm 105mm	S1 BCH 311 S1 BCH 312 S1 BCH 315 S1 BCH 400 S1 BCH 100mm S1 BCH 105mm	PH 6	4 15/16	16 3/4	6	2	14	15	4	10 3/4	Four 3/4	83.6	
4 3/16 4 7/16 4 1/2 110mm 115mm	S1 BCH 403 S1 BCH 407 S1 BCH 408 S1 BCH 110mm S1 BCH 115mm	PH 7	5 5/8	18 3/4	6 3/4	2 3/8	15 3/4	16 11/16	4 1/2	12 3/8	Two or Four 3/4	110	
4 15/16 5 120mm 125mm 130mm	S1 BCH 415 S1 BCH 500 S1 BCH 120mm S1 BCH 125mm S1 BCH 130mm	PH 8	6 3/8	20	7	1 1/2	17 1/4	18 3/16	4 3/4	14 3/4	Two or Four 3/4	175.9	
5 3/16 5 7/16 5 1/2 135mm 140mm	S1 BCH 503 S1 BCH 507 S1 BCH 508 S1 BCH 135mm S1 BCH 140mm	PH 9	7 1/8	22	7	1 9/16	18 1/2	19 1/2	4 3/4	15 7/8	Four 7/8	201.4	
5 15/16 6 150mm 155mm	S1 BCH 515 S1 BCH 600 S1 BCH 150mm S1 BCH 155mm	PH 10	7 1/8	22	7	1 5/8	19	20	4 3/4	16 1/4	Four 7/8	224.5	

*Specify suffix - FL for Float Bearing, HD for Held Bearing
 ** Base to center height can be altered upon request.
 Special application bearings are available upon request.
 † Housing width only, length through bore reference G.

Dimensions in inches
 Normal operating range for
 standard bearings is 32°F to 212°F.

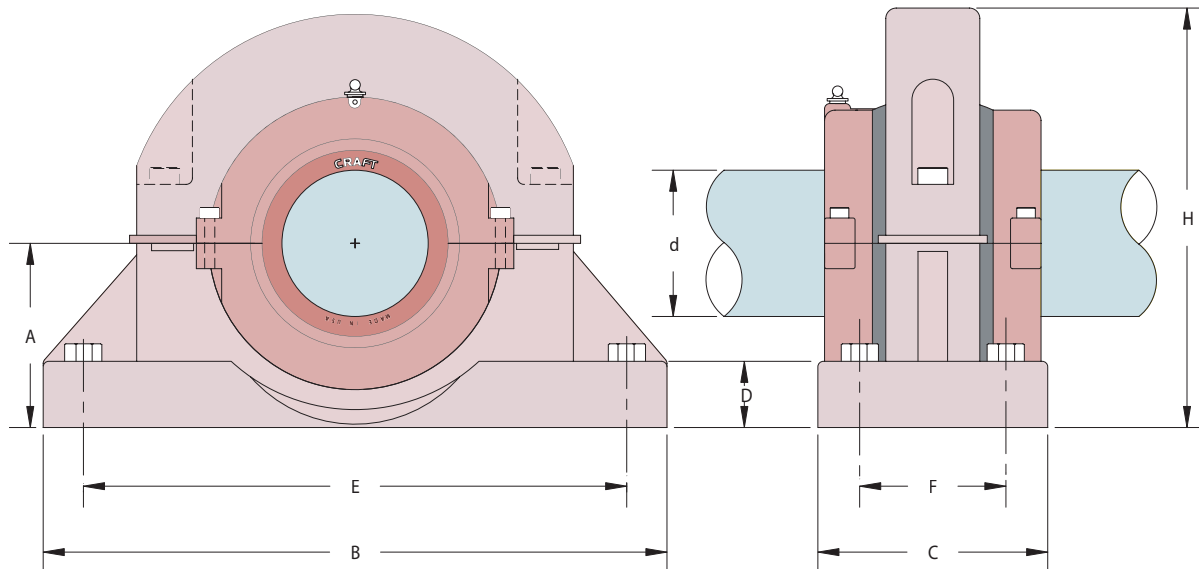

S1 SERIES SMALL BORE

CARTRIDGE ASSEMBLY						
Shaft Diameter	Cartridge* Assembly	Cartridge	L	G†	Weight lbs.	Grease Capacity
1 7/16 1 1/2 40mm	S1 BC 107 S1 BC 108 S1 BC 40mm	S1 C 108	3 15/16	3 3/8	6.9	2.0 oz.
1 11/16 1 3/4 1 15/16 2 45mm 50mm	S1 BC 111 S1 BC 112 S1 BC 115 S1 BC 200 S1 BC 45mm S1 BC 50mm	S1 C 200	4 5/8	3 13/16	9.2	3.2 oz.
2 3/16 2 1/4 2 7/16 2 1/2 60mm 65mm	S1 BC 203 S1 BC 204 S1 BC 207 S1 BC 208 S1 BC 60mm S1 BC 65mm	S1 C 208	5 5/16	4 1/16	11.6	5.2 oz.
2 11/16 2 3/4 2 15/16 3 70mm 75mm	S1 BC 211 S1 BC 212 S1 BC 215 S1 BC 300 S1 BC 70mm S1 BC 75mm	S1 C 300	6 3/16	4 3/8	18.5	6.2 oz.
3 3/16 3 1/4 3 7/16 3 1/2 80mm 85mm 90mm	S1 BC 303 S1 BC 304 S1 BC 307 S1 BC 308 S1 BC 80mm S1 BC 85mm S1 BC 90mm	S1 C 308	7	5 5/16	25.5	10.5 oz.
3 11/16 3 3/4 3 15/16 4 100mm 105mm	S1 BC 311 S1 BC 312 S1 BC 315 S1 BC 400 S1 BC 100mm S1 BC 105mm	S1 C 400	8	5 1/4	32.3	12.5 oz.
4 3/16 4 7/16 4 1/2 110mm 115mm	S1 BC 403 S1 BC 407 S1 BC 408 S1 BC 110mm S1 BC 115mm	S1 C 408	9 1/8	5 5/8	48.6	1.2 Lbs.
4 15/16 5 120mm 125mm 130mm	S1 BC 415 S1 BC 500 S1 BC 120mm S1 BC 125mm S1 BC 130mm	S1 C 500	10 1/2	6 1/8	71.7	1.4 Lbs.
5 3/16 5 7/16 5 1/2 135mm 140mm	S1 BC 503 S1 BC 507 S1 BC 508 S1 BC 135mm S1 BC 140mm	S1 C 508	11	6 5/8	81.1	1.8 Lbs.
5 15/16 6 150mm 155mm	S1 BC 515 S1 BC 600 S1 BC 150mm S1 BC 155mm	S1 C 600	11 5/8	6 7/8	97	2.0 Lbs.

ROLLER BEARING								
Bearing*	Bearing Rating Lbs.			Max. RPM	Do	Wi	Wo	Weight lbs.
	Dynamic Cr	Static Co	Axial Ca**					
S1 B 107 S1 B 108 S1 B 40mm	13870	15560	285	5420	3.313	1.972	0.938	2.3
S1 B 111 S1 B 112 S1 B 115 S1 B 200 S1 B 45mm S1 B 50mm	15954	18747	272	4460	3.875	2.192	1.000	3.5
S1 B 203 S1 B 204 S1 B 207 S1 B 208 S1 B 60mm S1 B 65mm	20255	24851	351	3750	4.500	2.192	1.063	3.5
S1 B 211 S1 B 212 S1 B 215 S1 B 300 S1 B 70mm S1 B 75mm	29843	40077	433	3190	5.250	2.410	1.250	6.0
S1 B 303 S1 B 304 S1 B 307 S1 B 308 S1 B 80mm S1 B 85mm S1 B 90mm	37552	52749	453	2740	6.000	2.781	1.531	9.2
S1 B 311 S1 B 312 S1 B 315 S1 B 400 S1 B 100mm S1 B 105mm	51215	73061	552	2400	6.875	3.188	1.781	13.9
S1 B 403 S1 B 407 S1 B 408 S1 B 110mm S1 B 115mm	63207	94628	654	2140	8.000	3.342	1.844	20.8
S1 B 415 S1 B 500 S1 B 120mm S1 B 125mm S1 B 130mm	72821	111390	685	1940	8.750	3.531	2.125	25.5
S1 B 503 S1 B 507 S1 B 508 S1 B 135mm S1 B 140mm	80703	124806	717	1780	9.500	3.875	2.188	32.4
S1 B 515 S1 B 600 S1 B 150mm S1 B 155mm	87598	141757	762	1670	10.000	3.875	2.188	37.1

*Specify suffix - FL for Float Bearing
- HD for Held Bearing

**Based on Axial Capacity at 1000 RPM.

† Length through Bore.

Dimensions in inches

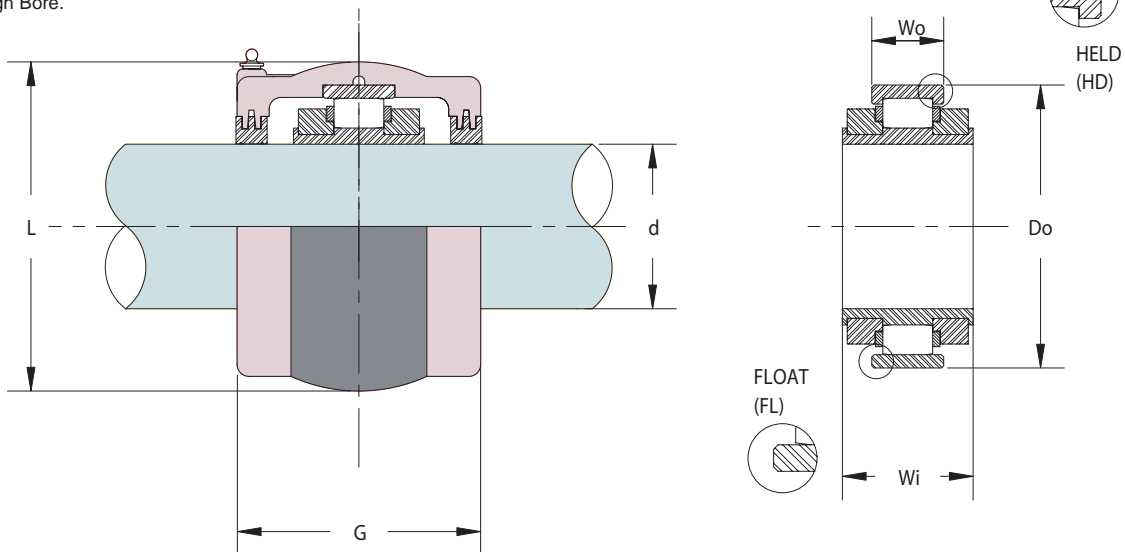

S1 SERIES LARGE BORE

MOUNTED UNIT												
Shaft Diameter	Complete* Component	Pedestal Housing	A **	B	C †	D	E		F	H	Bolts	Weight lbs.
							Minimum	Maximum				
6 7/16 6 1/2 160mm	S1 BCH 607 S1 BCH 608 S1 BCH 160mm	PH 11	8 3/8	20	7	1 1/4	14	15	4 1/2	17	Four 1	236
6 15/16 7 170mm 180mm	S1 BCH 615 S1 BCH 700 S1 BCH 170mm S1 BCH 180mm	PH 12	9 1/4	21	7 1/2	1 3/8	14 3/4	15 3/4	5	18 1/2	Four 1	283
7 15/16 8 190mm 200mm	S1 BCH 715 S1 BCH 800 S1 BCH 190mm S1 BCH 200mm	PH 13	9 3/4	22 1/2	8	1 1/2	16 1/8	17 1/8	5 1/2	19 1/2	Four 1	321
8 1/2 9 220mm	S1 BCH 808 S1 BCH 900 S1 BCH 220mm	PH 14	10 5/8	25	8 1/2	1 5/8	17 3/8	18 7/8	5 1/2	21 1/4	Four 1 1/4	372
9 1/2 10 240mm	S1 BCH 908 S1 BCH 1000 S1 BCH 240mm	PH 15	11 1/2	27	9	1 3/4	19	20 1/2	5 1/2	23	Four 1 1/4	512
11 260mm 280mm	S1 BCH 1100 S1 BCH 260mm S1 BCH 280mm	PH 16	12 1/4	28 1/2	9	1 7/8	20 1/4	21 3/4	5 1/2	24 1/2	Four 1 1/4	605
12 300mm	S1 BCH 1200 S1 BCH 300mm	PH 17	13 1/2	30	10	2	22 1/4	23 3/4	7	27	Four 1 1/4	742

*Specify suffix - FL for Float Bearing, HD for Held Bearing
 **Base to center height can be altered upon request.
 Special application bearings are available upon request.
 † Housing width only, length through bore reference G.

Dimensions in inches
 Normal operating range for standard bearings is 32°F to 212°F.

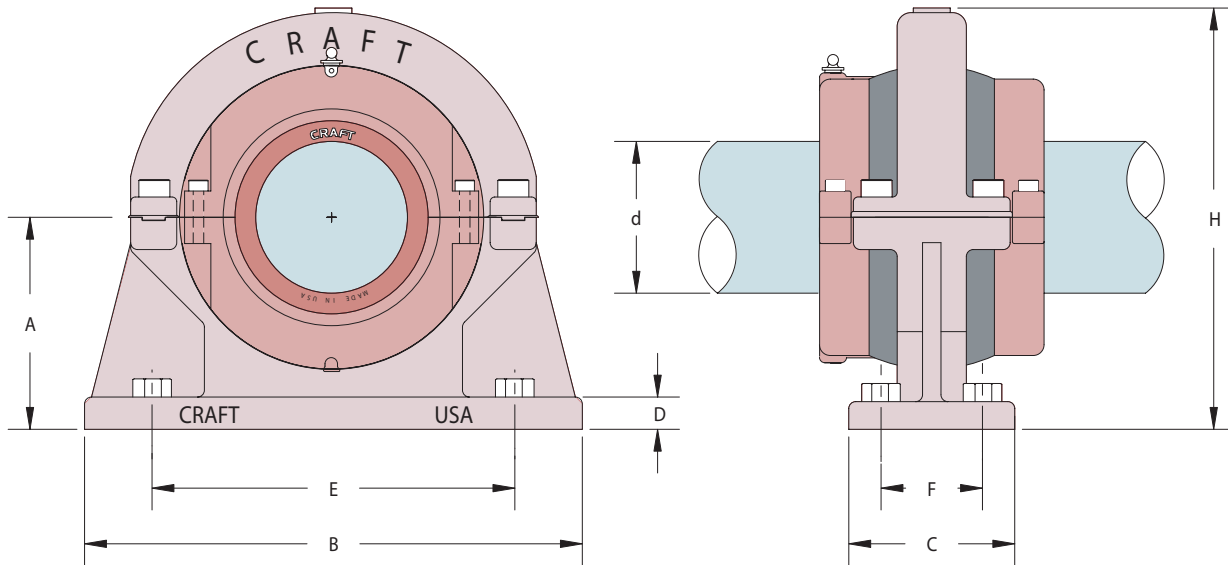

S1 SERIES LARGE BORE

CARTRIDGE ASSEMBLY						
Shaft Diameter	Cartridge* Assembly	Cartridge	L	G†	Weight lbs.	Grease Capacity
6 7/16 6 1/2 160mm	S1 BC 607 S1 BC 608 S1 BC 160mm	S1 C 608	12 1/4	7 9/16	110	2.1 Lbs.
6 15/16 7 170mm 180mm	S1 BC 615 S1 BC 700 S1 BC 170mm S1 BC 180mm	S1 C 700	12 3/4	7 7/8	137	2.4 Lbs.
7 15/16 8 190mm 200mm	S1 BC 715 S1 BC 800 S1 BC 190mm S1 BC 200mm	S1 C 800	14 1/8	7 7/8	151	3.2 Lbs.
8 1/2 9 220mm	S1 BC 808 S1 BC 900 S1 BC 220mm	S1 C 900	15 1/4	8 1/2	174	3.3 Lbs.
9 1/2 10 240mm	S1 BC 908 S1 BC 1000 S1 BC 240mm	S1 C 1000	16 1/2	8 3/4	227	4.2 Lbs.
11 260mm 280mm	S1 BC 1100 S1 BC 260mm S1 BC 280mm	S1 C 1100	17 7/8	9 1/8	279	4.2 Lbs.
12 300mm	S1 BC 1200 S1 BC 300mm	S1 C 1200	19 1/4	9 3/4	337	4.4 Lbs.

Bearing*	Bearing Rating Lbs.			Max. RPM	Do	Wi	Wo	Weight lbs.
	Dynamic Cr	Static Co	Axial Ca**					
S1 B 607 S1 B 608 S1 B 160mm	97258	159049	7993	1420	10.75	4.291	2.375	47
S1 B 615 S1 B 700 S1 B 170mm S1 B 180mm	104510	178085	8445	1300	11.25	4.291	2.185	46
S1 B 715 S1 B 800 S1 B 190mm S1 B 200mm	110607	198444	8459	1130	12.25	4.291	2.375	50
S1 B 808 S1 B 900 S1 B 220mm	121869	223077	8566	970	13.50	4.528	2.500	63
S1 B 908 S1 B 1000 S1 B 240mm	136054	266300	9280	860	14.75	4.803	2.625	82
S1 B 1100 S1 B 260mm S1 B 280mm	156486	303690	9679	760	16.00	5.039	2.719	100
S1 B 1200 S1 B 300mm	163906	331580	9743	680	17.25	5.625	2.938	123

Dimensions in inches

*Specify suffix - FL for Float Bearing
 - HD for Held Bearing
 **Based on Axial Capacity at 100 RPM.
 † Length through Bore.

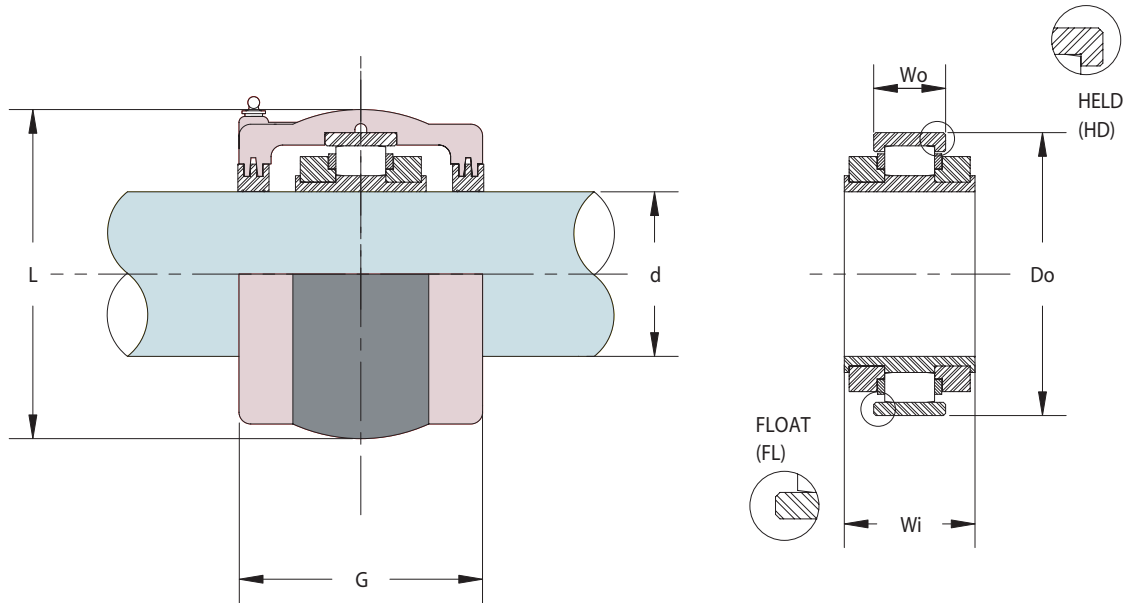

S1 SERIES SMALL BORE FLANGE

FLANGE UNIT											
Shaft Diameter	Complete Component*	Flange Housing	Y	K	X	Z	S	T	P	Bolts	Weight lbs.
2 3/16 2 1/4 2 7/16 2 1/2 60mm 65mm	S1 BCF 203 S1 BCF 204 S1 BCF 207 S1 BCF 208 S1 BCF 60mm S1 BCF 65mm	FH 3	10 1/4	4 11/16	2 5/8	8 9/16	6 1/16	5/8	6 9/16	Four 1/2	37
2 11/16 2 3/4 2 15/16 3 70mm 75mm	S1 BCF 211 S1 BCF 212 S1 BCF 215 S1 BCF 300 S1 BCF 70mm S1 BCF 75mm	FH 4	11 1/4	5 1/8	2 7/8	9 9/16	6 3/4	5/8	7 9/16	Four 1/2	53
3 3/16 3 1/4 3 7/16 3 1/2 80mm 85mm 90mm	S1 BCF 303 S1 BCF 304 S1 BCF 307 S1 BCF 308 S1 BCF 80mm S1 BCF 85mm S1 BCF 90mm	FH 5	13	5 13/16	3 1/8	10 3/4	7 5/8	3/4	8 1/2	Four 5/8	80
3 11/16 3 3/4 3 15/16 4 100mm 105mm	S1 BCF 311 S1 BCF 312 S1 BCF 315 S1 BCF 400 S1 BCF 100mm S1 BCF 105mm	FH 6	14	6	3 3/8	11 7/8	8 3/8	3/4	9 5/8	Four 5/8	94
4 3/16 4 7/16 4 1/2 110mm 115mm	S1 BCF 403 S1 BCF 407 S1 BCF 408 S1 BCF 110mm S1 BCF 115mm	FH 7	15	6 7/8	3 5/8	13 1/8	9 5/16	7/8	10 7/8	Four 5/8	122
4 15/16 5 120mm 125mm 130mm	S1 BCF 415 S1 BCF 500 S1 BCF 120mm S1 BCF 125mm S1 BCF 130mm	FH 8	17	6 15/16	3 7/8	14 3/4	10 7/16	7/8	12 3/8	Four 7/8	165
5 3/16 5 7/16 5 1/2 135mm 140mm	S1 BCF 503 S1 BCF 507 S1 BCF 508 S1 BCF 135mm S1 BCF 140mm	FH 9	17 1/2	7 3/16	3 7/8	15 1/8	10 11/16	1	12 1/2	Four 7/8	181
5 15/16 6 150mm 155mm	S1 BCF 515 S1 BCF 600 S1 BCF 150mm S1 BCF 155mm	FH 10	18 1/2	7 15/16	4 1/2	16 1/4	11 1/2	1	13 5/8	Four 1	215

*Specify suffix - FL for Float Bearing, HD for Held Bearing
Special application bearings are available upon request.

Dimensions in inches
Normal operating range for standard bearings is 32°F to 212°F.

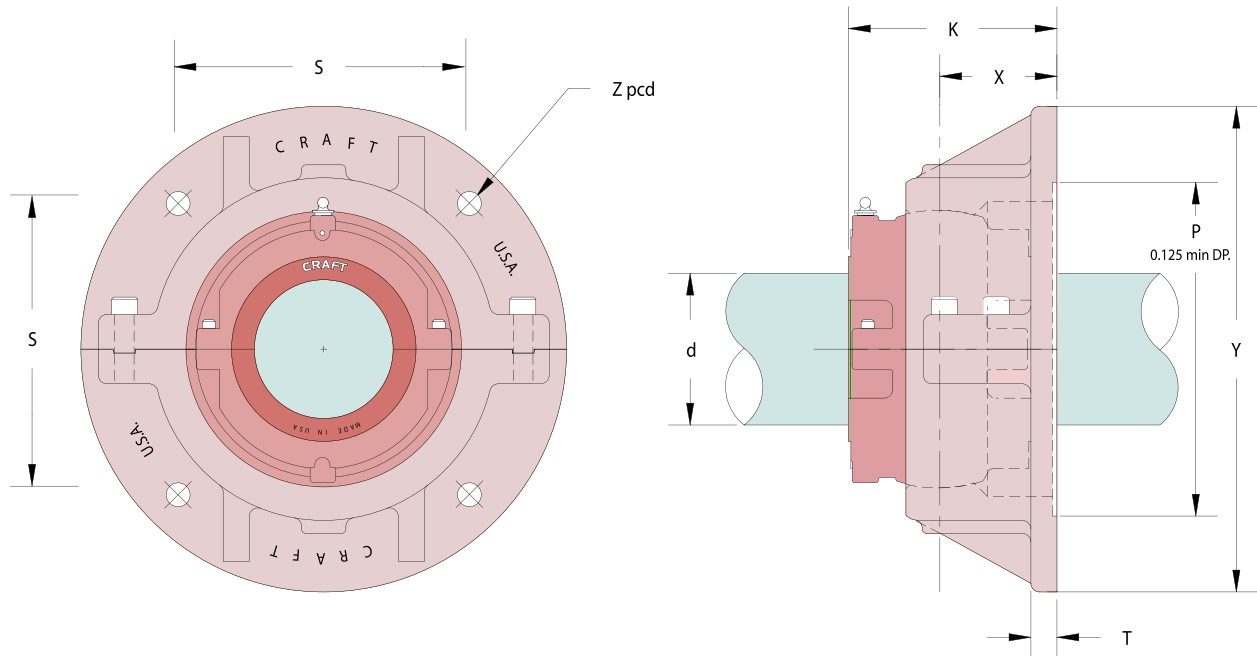

S1 SERIES LARGE BORE FLANGE

FLANGE UNIT											
Shaft Diameter	Complete Component*	Flange Housing	Y	K	X	Z	S	T	P	Bolts	Weight lbs.
6 7/16 6 1/2 160mm	S1 BCF 607 S1 BCF 608 S1 BCF 160mm	FH 11	19 1/2	7 15/16	4 1/8	16 3/4	11 7/8	1	13 7/8	Four 1	242
6 15/16 7 170mm 180mm	S1 BCF 615 S1 BCF 700 S1 BCF 170mm S1 BCF 180mm	FH 12	20	8 3/16	4 1/4	17 1/4	12 3/16	1 1/8	14 3/8	Four 1	255
7 15/16 8 190mm 200mm	S1 BCF 715 S1 BCF 800 S1 BCF 190mm S1 BCF 200mm	FH 13	21	8 3/16	4 1/4	18 5/8	13 3/16	1 1/4	15 3/4	Four 1	306
8 1/2 9 220mm	S1 BCF 808 S1 BCF 900 S1 BCF 220mm	FH 14	23	8 7/8	4 5/8	20 1/8	14 1/4	1 3/8	17	Four 1 1/4	365
9 1/2 10 240mm	S1 CF 908 S1 BCF 1000 S1 BCF 240mm	FH 15	24	9	4 5/8	21 3/8	15 1/16	1 3/8	18 1/4	Four 1 1/4	407
11 260mm 280mm	S1 BCF 1100 S1 BCF 260mm S1 BCF 280mm	FH 16	26	9 7/16	4 7/8	23	16 1/4	1 1/2	19 7/8	Four 1 1/4	521
12 300mm	S1 BCF 1200 S1 BCF 300mm	FH 17	28	10 1/8	5 1/4	24 5/8	17 7/16	1 1/2	21 1/4	Four 1 1/4	642

*Specify suffix - FL for Float Bearing, HD for Held Bearing
Special application bearings are available upon request.

Dimensions in inches

S1 Series Load Chart (pounds)																					
Bearing Group	Max. RPM	50 RPM		100 RPM		500 RPM		750 RPM		1000 RPM		1250 RPM		1500 RPM		1800 RPM		2500 RPM		3600 RPM	
		Pr	Pa	Pr	Pa	Pr	Pa	Pr	Pa	Pr	Pa	Pr	Pa	Pr	Pa	Pr	Pa	Pr	Pa	Pr	Pa
S1-108	5420	2997	778	2434	778	1502	570	1330	380	1220	285	1141	228	1080	190	1023	158	927	114	830	79
S1-200	4460	3447	937	2800	937	1728	544	1530	363	1403	272	1312	218	1242	181	1176	151	1066	109	955	76
S1-208	3750	4376	1243	3554	1243	2193	702	1942	468	1781	351	1666	281	1577	234	1493	195	1353	140	1213	98
S1-300	3190	6447	2004	5237	2004	3231	866	2861	577	2625	433	2455	346	2324	289	2200	241	1994	173	1787	120
S1-308	2740	8113	2637	6590	2637	4066	906	3600	604	3303	453	3089	362	2924	302	2769	252	2509	181	X	X
S1-400	2400	11065	3653	8987	3653	5546	1104	4910	736	4504	552	4213	442	3988	368	3776	307	3421	221	X	X
S1-408	2140	13656	4731	11092	4731	6844	1308	6060	872	5559	654	5199	523	4922	436	4660	363	X	X	X	X
S1-500	1940	15733	5570	12779	5570	7885	1370	6982	913	6405	685	5990	548	5671	456	5369	381	X	X	X	X
S1-508	1780	17436	6240	14162	6240	8739	1434	7738	956	7098	717	6638	573	6285	478	X	X	X	X	X	X
S1-600	1670	18925	7088	15372	7088	9485	1524	8399	1016	7704	762	7205	610	6822	508	X	X	X	X	X	X
S1-608	1420	21012	7952	17067	7952	10531	1598	9325	1065	8554	799	8000	639	X	X	X	X	X	X	X	X
S1-700	1300	22579	8904	18340	8450	11316	1690	10020	1127	9192	845	8597	676	X	X	X	X	X	X	X	X
S1-800	1130	23896	9922	19410	8460	11977	1692	10605	1128	9728	846	X	X	X	X	X	X	X	X	X	X
S1-900	970	26329	11154	21386	8570	13196	1714	11685	1143	X	X	X	X	X	X	X	X	X	X	X	X
S1-1000	860	29394	13315	23875	9280	14732	1856	13045	1237	X	X	X	X	X	X	X	X	X	X	X	X
S1-1100	760	33808	15184	27461	9680	16944	1936	15004	1291	X	X	X	X	X	X	X	X	X	X	X	X
S1-1200	680	35411	16579	28763	9740	17748	1948	X	X	X	X	X	X	X	X	X	X	X	X	X	X

Radial Load: $Pr \leq \frac{Cr}{fd} \times \left(\frac{16667}{n \times L_{10}}\right)^3$ Axial Load: $Pa \leq \frac{Ca \times SF}{n}$ or $.05 \times Co$, whichever is less
 SF = speed factor = 1000 RPM for small bore (600 group and below)
 100 RPM for large bore (608 group and above)

Cr=Dynamic Radial Load Rating Co=Static Radial Load Rating
 Ca=Dynamic Axial Load Rating n=RPM

Above ratings are based upon a minimum life of 30,000 hours (L10) and utilization of EP grease, and a service factor (fd) of 1.2.

S2 SERIES SMALL BORE

MOUNTED UNIT												
Shaft Diameter	Complete* Component	Pedestal Housing	A **	B	C †	D	E		F	H	Bolts	Weight lbs.
							Minimum	Maximum				
2 3/16 2 1/4 2 7/16 2 1/2 60mm 65mm	S2 BCH 203 S2 BCH 204 S2 BCH 207 S2 BCH 208 S2 BCH 60mm S2 BCH 65mm	PH 4	3 3/4	13	3	1 1/2	10 1/4	11	-	8 1/8	Two 3/4	39
2 11/16 2 3/4 2 15/16 3 70mm 75mm	S2 BCH 211 S2 BCH 212 S2 BCH 215 S2 BCH 300 S2 BCH 70mm S2 BCH 75mm	PH 5	4 13/32	15	5 1/2	1 3/4	12 7/16	13 3/8	3 1/2	10	Four 3/4	74
3 3/16 3 1/4 3 7/16 3 1/2 80mm 85mm 90mm	S2 BCH 303 S2 BCH 304 S2 BCH 307 S2 BCH 308 S2 BCH 80mm S2 BCH 85mm S2 BCH 90mm	PH 6	4 15/16	16 3/4	6	2	14	15	4	10 3/4	Four 3/4	88
3 11/16 3 3/4 3 15/16 4 100mm 105mm	S2 BCH 311 S2 BCH 312 S2 BCH 315 S2 BCH 400 S2 BCH 100mm S2 BCH 105mm	PH 7	5 5/8	18 3/4	6 3/4	2 3/8	15 3/4	16 11/16	4 1/2	12 3/8	Four 3/4	118
4 3/16 4 7/16 4 1/2 110mm 115mm	S2 BCH 403 S2 BCH 407 S2 BCH 408 S2 BCH 110mm S2 BCH 115mm	PH 8	6 3/8	20	7	1 1/2	17 1/4	18 3/16	4 3/4	14 3/4	Four 7/8	166
4 15/16 5 120mm 125mm 130mm	S2 BCH 415 S2 BCH 500 S2 BCH 120mm S2 BCH 125mm S2 BCH 130mm	PH 10	7 1/8	22	7	1 5/8	19	20	4 3/4	16 1/4	Four 7/8	234
5 3/16 5 7/16 5 1/2 140mm	S2 BCH 503 S2 BCH 507 S2 BCH 508 S2 BCH 140mm	PH 20	8	24	7	2	21	22	4 3/4	18	Four 1	320
5 15/16 6 150mm 155mm	S2 BCH 515 S2 BCH 600 S2 BCH 150mm S2 BCH 155mm	PH 21	8 1/4	25	8	2	21 1/2	22 1/2	5	18 1/2	Four 1	374

*Specify suffix - FL for Float Bearing, HD for Held Bearing
 **Base to center height can be altered upon request.
 Special application bearings are available upon request.
 † Housing width only, length through bore reference G.

Dimensions in inches
 Normal operating range for standard bearings is 32°F to 212°F.

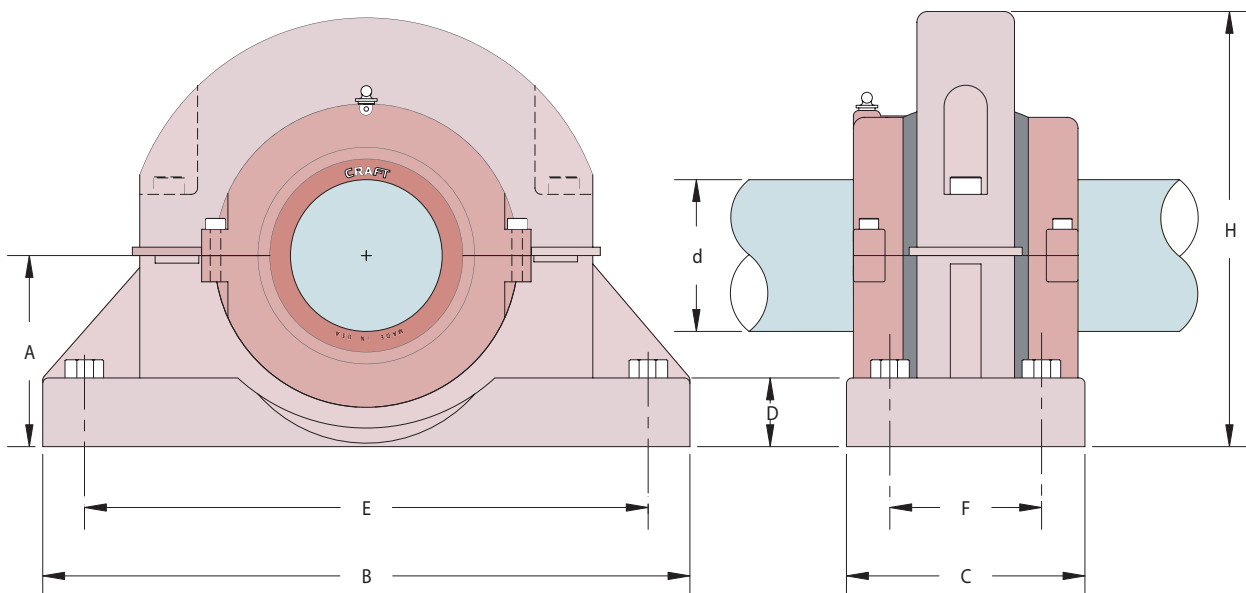

S2 SERIES SMALL BORE

CARTRIDGE ASSEMBLY						
Shaft Diameter	Cartridge* Assembly	Cartridge	L	G†	Weight lbs.	Grease Capacity
2 3/16 2 1/4 2 7/16 2 1/2 60mm 65mm	S2 BC 203 S2 BC 204 S2 BC 207 S2 BC 208 S2 BC 60mm S2 BC 65mm	S2 C 208	6 3/16	4 15/16	24.2	7.6 oz.
2 11/16 2 3/4 2 15/16 3 70mm 75mm	S2 BC 211 S2 BC 212 S2 BC 215 S2 BC 300 S2 BC 70mm S2 BC 75mm	S2 C 300	7	5 1/2	34	10.5 oz.
3 3/16 3 1/4 3 7/16 3 1/2 80mm 85mm 90mm	S2 BC 303 S2 BC 304 S2 BC 307 S2 BC 308 S2 BC 80mm S2 BC 85mm S2 BC 90mm	S2 C 308	8	6 1/16	41.3	1.1 Lbs.
3 11/16 3 3/4 3 15/16 4 100mm 105mm	S2 BC 311 S2 BC 312 S2 BC 315 S2 BC 400 S2 BC 100mm S2 BC 105mm	S2 C 400	9 1/8	5 3/4	58	1.4 Lbs.
4 3/16 4 7/16 4 1/2 110mm 115mm	S2 BC 403 S2 BC 407 S2 BC 408 S2 BC 110mm S2 BC 115mm	S2 C 408	10 1/2	6 3/8	77.2	2.0 Lbs.
4 15/16 5 120mm 125mm 130mm	S2 BC 415 S2 BC 500 S2 BC 120mm S2 BC 125mm S2 BC 130mm	S2 C 500	11 5/8	7 1/4	111.5	2.5 Lbs.
5 3/16 5 7/16 5 1/2 140mm	S2 BC 503 S2 BC 507 S2 BC 508 S2 BC 140mm	S2 C 508	12 3/4	7 3/8	138.3	3.0 Lbs.
5 15/16 6 150mm 155mm	S2 BC 515 S2 BC 600 S2 BC 150mm S2 BC 155mm	S2 C 600	13 1/4	8	162	3.0 Lbs.

Bearing*	Bearing Rating Lbs.			Max. RPM	Do	Wi	Wo	Weight lbs.
	Dynamic Cr	Static Co	Axial Ca**					
S2 B 203 S2 B 204 S2 B 207 S2 B 208 S2 B 60mm S2 B 65mm	33580	42860	473	3450	5.000	2.844	1.531	7.7
S2 B 211 S2 B 212 S2 B 215 S2 B 300 S2 B 70mm S2 B 75mm	45420	59250	561	2930	5.875	3.250	1.813	12.1
S2 B 303 S2 B 304 S2 B 307 S2 B 308 S2 B 80mm S2 B 85mm S2 B 90mm	57430	79580	666	2550	6.688	3.528	1.906	17.6
S2 B 311 S2 B 312 S2 B 315 S2 B 400 S2 B 100mm S2 B 105mm	74130	105015	761	2230	7.625	3.622	2.031	21.8
S2 B 403 S2 B 407 S2 B 408 S2 B 110mm S2 B 115mm	91410	131140	857	1980	9.000	3.938	2.250	38.9
S2 B 415 S2 B 500 S2 B 120mm S2 B 125mm S2 B 130mm	111320	162690	951	1780	10.000	4.500	2.500	55
S2 B 503 S2 B 507 S2 B 508 S2 B 140mm	133640	197690	1060	1630	10.750	4.625	2.625	58.3
S2 B 515 S2 B 600 S2 B 150mm S2 B 155mm	147260	229200	1137	1450	11.500	4.875	2.688	70.4

*Specify suffix - FL for Float Bearing
 - HD for Held Bearing
 **Based on Axial Capacity at 1000 RPM.
 † Length through Bore.

Dimensions in inches

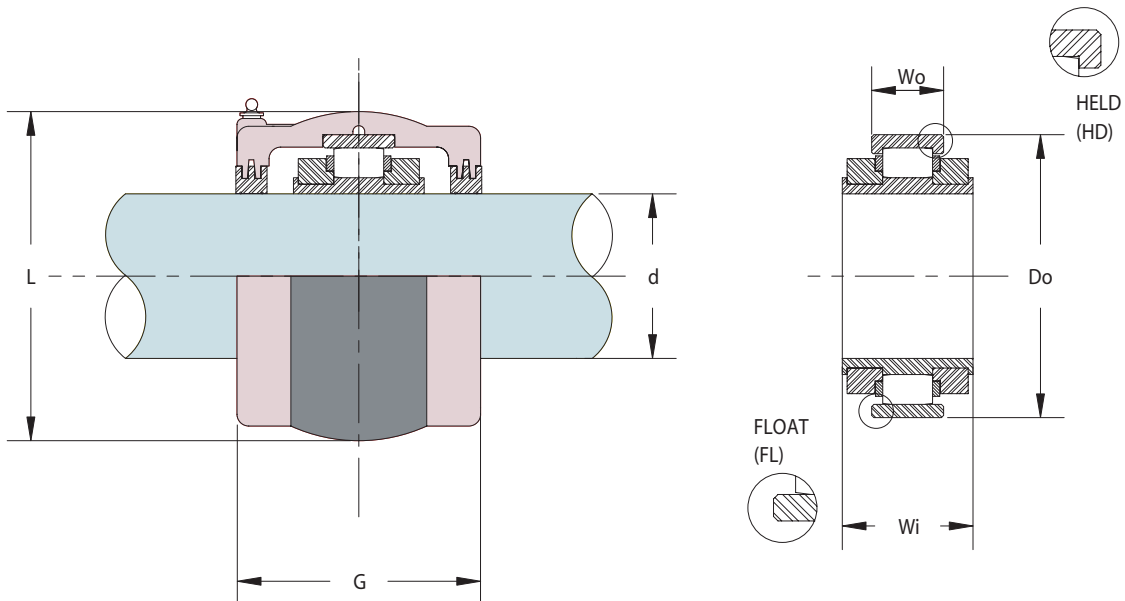

S2 SERIES LARGE BORE

MOUNTED UNIT												
Shaft Diameter	Complete* Component	Pedestal Housing	A **	B	C†	D	E		F	H	Bolts	Weight lbs.
							Minimum	Maximum				
6 7/16 6 1/2 160mm 170mm	S2 BCH 607 S2 BCH 608 S2 BCH 160mm S2 BCH 170mm	PH 22	10 1/2	23 1/2	9 1/2	1 3/4	16 7/8	18 3/8	6 3/4	21	Four 1 1/4	407
6 15/16 7 180mm	S2 BCH 615 S2 BCH 700 S2 BCH 180mm	PH 23	10 3/4	25	9 1/2	1 3/4	17 1/4	18 3/4	6 1/2	21 1/2	Four 1 1/4	478
7 15/16 8 190mm 200mm	S2 BCH 715 S2 BCH 800 S2 BCH 190mm S2 BCH 200mm	PH 24	12	27	10 1/2	2	19 1/4	20 3/4	7 1/2	24	Four 1 1/4	646
8 1/2 9 220mm	S2 BCH 808 S2 BCH 900 S2 BCH 220mm	PH 25	12 3/4	29 1/2	11	2	20 7/8	22 3/8	7 1/2	25 1/2	Four 1 1/4	807
10 240mm 260mm	S2 BCH 1000 S2 BCH 240mm S2 BCH 260mm	PH 26	14	32	11 1/2	2 1/8	22 3/4	24 1/4	8	28	Four 1 1/4	938
11 280mm	S2 BCH 1100 S2 BCH 280mm	PH 27	14 7/8	36	13	2 3/8	20 1/4	21 3/4	10	30	Eight 1 1/4	1126
12 300mm	S2 BCH 1200 S2 BCH 300mm	PH 28	15 1/2	37 3/4	13	2 3/8	21 1/2	23	10	31	Eight 1 1/4	1295

*Specify suffix - FL for Float Bearing, HD for Held Bearing

**Base to center height can be altered upon request.

Special application bearings are available upon request.

† Housing width only, length through bore reference G.

Dimensions in inches
Normal operating range for standard bearings is 32°F to 212°F.

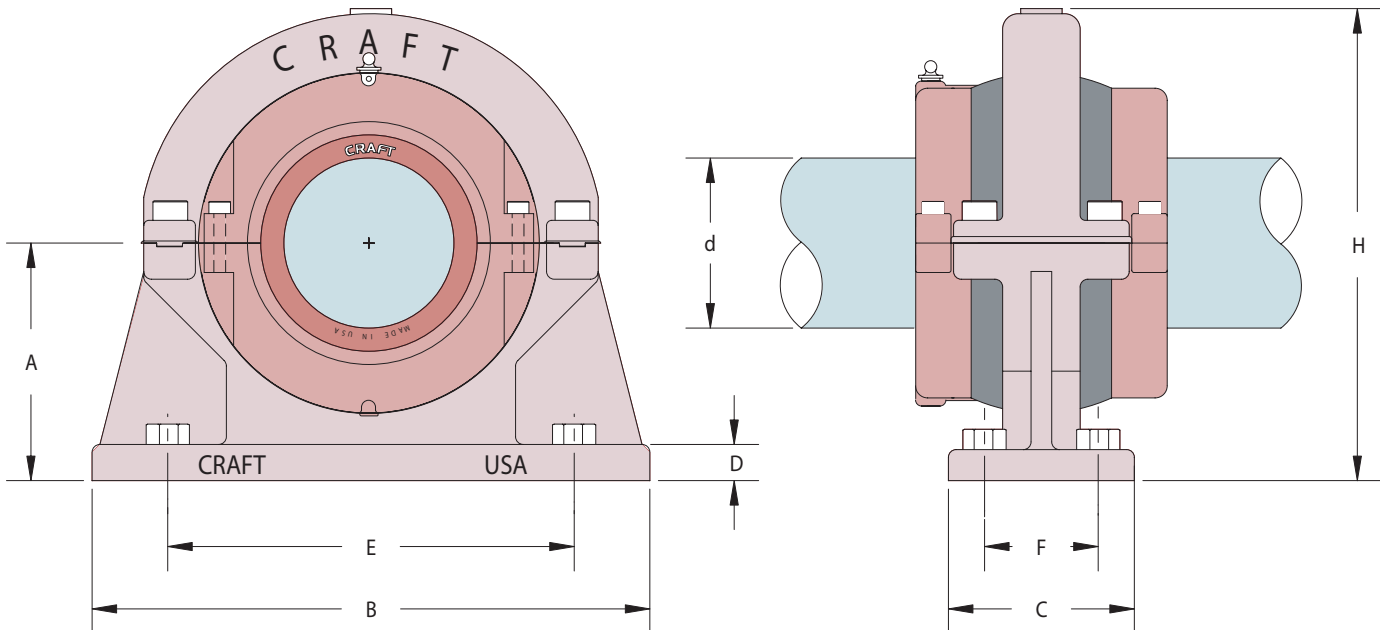

S2 SERIES LARGE BORE

CARTRIDGE ASSEMBLY						
Shaft Diameter	Cartridge* Assembly	Cartridge	L	G†	Weight lbs.	Grease Capacity
6 7/16 6 1/2 160mm 170mm	S2 BC 607 S2 BC 608 S2 BC 160mm S2 BC 170mm	S2 C 608	14 1/2	9 1/8	231	3.2 Lbs.
6 15/16 7 180mm	S2 BC 615 S2 BC 700 S2 BC 180mm	S2 C 700	15	9 17/32	268	4.3 Lbs.
7 15/16 8 190mm 200mm	S2 BC 715 S2 BC 800 S2 BC 190mm S2 BC 200mm	S2 C 800	16 3/4	10 5/32	345	5.9 Lbs.
8 1/2 9 220mm	S2 BC 808 S2 BC 900 S2 BC 220mm	S2 C 900	18	10 25/32	364	8.0 Lbs.
10 240mm 260mm	S2 BC 1000 S2 BC 240mm S2 BC 260mm	S2 C 1000	19 1/2	11 1/32	440	8.9 Lbs.
11 280mm	S2 BC 1100 S2 BC 280mm	S2 C 1100	20 3/4	11 13/16	525	10.4 Lbs.
12 300mm	S2 BC 1200 S2 BC 300mm	S2 C 1200	21 3/4	12 1/16	600	11.8 Lbs.

Bearing*	Bearing Rating Lbs.			Max. RPM	Do	Wi	Wo	Weight lbs.
	Dynamic Cr	Static Co	Axial Ca**					
S2 B 607 S2 B 608 S2 B 160mm S2 B 170mm	156150	237650	10900	1300	12.500	5.500	3.28	93.5
S2 B 615 S2 B 700 S2 B 180mm	173550	258410	11910	1210	13.000	5.500	3.28	110
S2 B 715 S2 B 800 S2 B 190mm S2 B 200mm	199920	325750	12490	1040	14.500	6.141	3.56	134
S2 B 808 S2 B 900 S2 B 220mm	216740	371520	13040	930	15.500	6.402	3.56	148
S2 B 1000 S2 B 240mm S2 B 260mm	247490	431020	13760	830	17.000	6.668	3.81	187
S2 B 1100 S2 B 280mm	281170	496240	14600	750	18.250	7.323	4.00	209
S2 B 1200 S2 B 300mm	301890	557180	15180	690	19.500	7.594	4.06	297

*Specify suffix - FL for Float Bearing
 - HD for Held Bearing
 **Based on Axial Capacity at 100 RPM.
 † Length through Bore.

Dimensions in inches

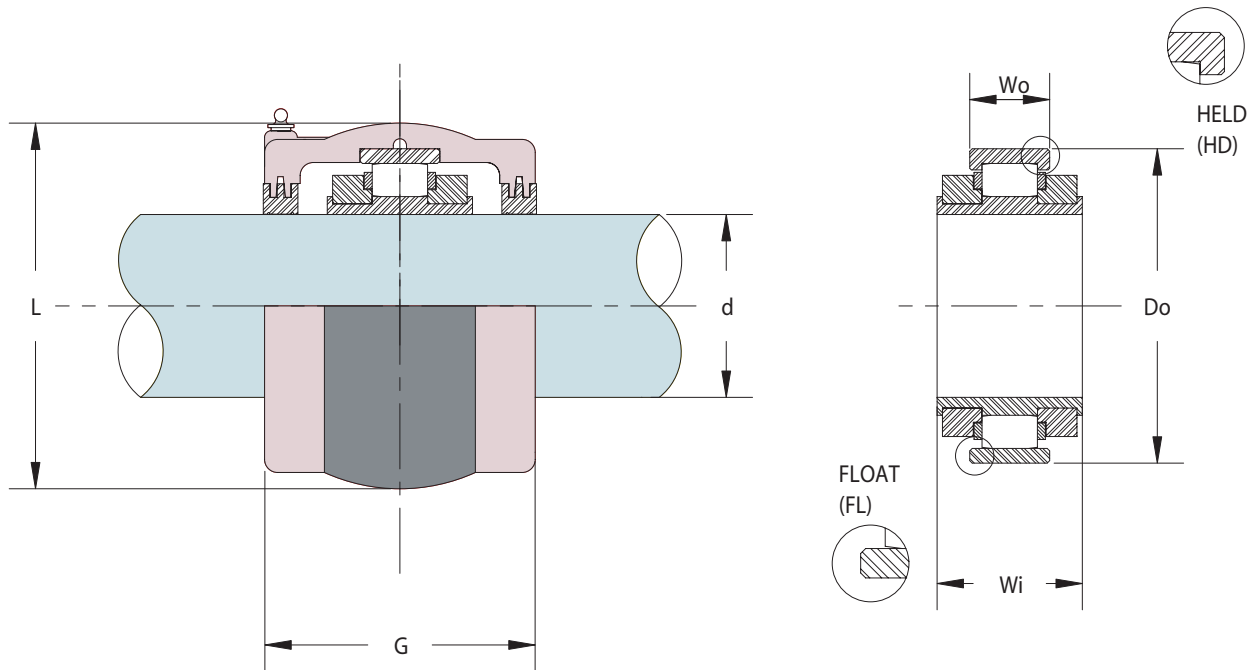

S2 SERIES SMALL BORE FLANGE

FLANGE UNIT											
Shaft Diameter	Complete Component*	Flange Housing	Y	K	X	Z	S	T	P	Bolts	Weight lbs.
2 3/16 2 1/4 2 7/16 2 1/2 60mm 65mm	S2 BCF 203 S2 BCF 204 S2 BCF 207 S2 BCF 208 S2 BCF 60mm S2 BCF 65mm	FH 4	11 1/4	5 3/8	2 7/8	9 9/16	6 3/4	5/8	7 9/16	Four 1/2	37
2 11/16 2 3/4 2 15/16 3 70mm 75mm	S2 BCF 211 S2 BCF 212 S2 BCF 215 S2 BCF 300 S2 BCF 70mm S2 BCF 75mm	FH 5	13	5 7/8	3 1/8	10 3/4	7 5/8	3/4	8 1/2	Four 5/8	53
3 3/16 3 1/4 3 7/16 3 1/2 80mm 85mm 90mm	S2 BCF 303 S2 BCF 304 S2 BCF 307 S2 BCF 308 S2 BCF 80mm S2 BCF 85mm S2 BCF 90mm	FH 6	14	6 7/16	3 3/8	11 7/8	8 3/4	3/4	9 5/8	Four 5/8	80
3 11/16 3 3/4 3 15/16 4 100mm 105mm	S2 BCF 311 S2 BCF 312 S2 BCF 315 S2 BCF 400 S2 BCF 100mm S2 BCF 105mm	FH 7	15	6 1/2	3 5/8	13 1/8	9 5/16	7/8	10 7/8	Four 5/8	94
4 3/16 4 7/16 4 1/2 110mm 115mm	S2 BCF 403 S2 BCF 407 S2 BCF 408 S2 BCF 110mm S2 BCF 115mm	FH 8	17	7 1/16	3 7/8	14 3/4	10 3/8	7/8	12 3/8	Four 7/8	181
4 15/16 5 120mm 125mm 130mm	S2 BCF 415 S2 BCF 500 S2 BCF 120mm S2 BCF 125mm S2 BCF 130mm	FH 10	18 1/2	8 1/8	4 1/2	16 1/4	11 1/2	1	13 5/8	Four 7/8	242
5 3/16 5 7/16 5 1/2 140mm	S2 BCF 503 S2 BCF 507 S2 BCF 508 S2 BCF 140mm	FH 20	20	8 3/16	4 1/4	17 1/2	12 3/8	1	14 7/8	Four 7/8	290
5 15/16 6 150mm	S2 BCF 515 S2 BCF 600 S2 BCF 150mm	FH 21	21	8 7/8	4 7/8	18 3/8	13	1	15 1/2	Four 1	340

*Specify suffix - FL for Float Bearing, HD for Held Bearing
Special application bearings are available upon request.

Dimensions in inches
Normal operating range for standard bearings is 32°F to 212°F.

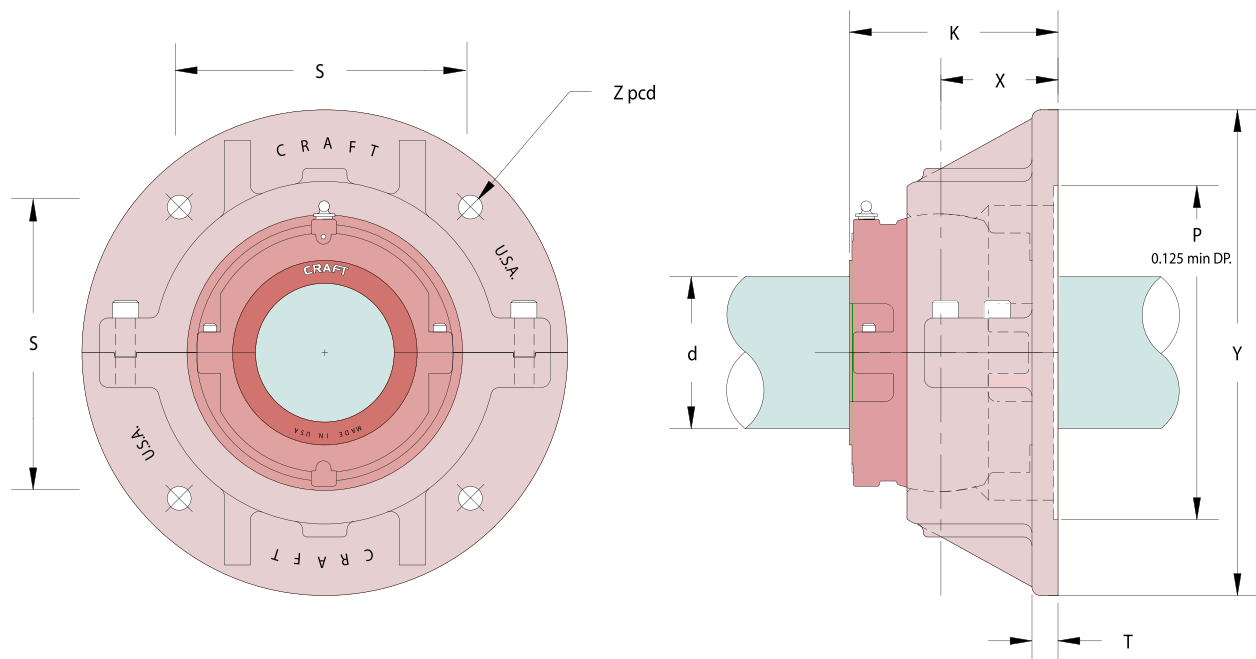

S2 SERIES LARGE BORE FLANGE

FLANGE UNIT											
Shaft Diameter	Complete Component*	Flange Housing	Y	K	X	Z	S	T	P	Bolts	Weight lbs.
6 7/16 6 1/2 160mm 170mm	S2 BCF 607 S2 BCF 608 S2 BCF 160mm S2 BCF 170mm	FH 22	23	9 7/16	4 7/8	20	14 1/8	1 1/8	16 7/8	Four 1 1/4	412
6 15/16 7 180mm	S2 BCF 615 S2 BCF 700 S2 BCF 180mm	FH 23	23 1/2	9 7/8	5 1/8	20 5/8	14 9/16	1 1/4	17 1/2	Four 1	509
7 15/16 8 190mm 200mm	S2 BCF 715 S2 BCF 800 S2 BCF 190mm S2 BCF 200mm	FH 24	25 1/2	10 7/16	5 3/8	22 1/2	15 13/16	1 1/4	19 3/8	Four 1	704
8 1/2 9 220mm	S2 BCF 808 S2 BCF 900 S2 BCF 220mm	FH 25	28	11 1/8	5 3/4	24 3/4	17 1/4	1 3/8	20 3/4	Four 1 1/4	771
10 240mm	S2 BCF 1000 S2 BCF 240mm	FH 26	29	11 3/8	5 7/8	26	18 3/8	1 1/2	22 3/8	Four 1 1/4	825
11 260mm 280mm	S2 BCF 1100 S2 BCF 260mm S2 BCF 280mm	FH 27	30	12 1/8	6 1/4	26 7/8	19	1 1/2	23 3/4	Eight 1 1/4	957
12 300mm	S2 BCF 1200 S2 BCF 300mm	FH 28	31	12 3/8	6 3/8	27 7/8	19 11/16	1 5/8	24 3/4	Eight 1 1/4	1082

*Specify suffix - FL for Float Bearing, HD for Held Bearing
Special application bearings are available upon request.

Dimensions in inches

S2 Series Load Chart (pounds)																					
Bearing Group	Max. RPM	50 RPM		100 RPM		500 RPM		750 RPM		1000 RPM		1250 RPM		1500 RPM		1800 RPM		2500 RPM		3600 RPM	
		Pr	Pa	Pr	Pa	Pr	Pa	Pr	Pa	Pr	Pa	Pr	Pa	Pr	Pa	Pr	Pa	Pr	Pa	Pr	Pa
S2-208	3450	7687	2143	6244	2143	3853	946	3411	631	3129	473	2927	378	2771	315	2623	263	2377	189	2131	131
S2-300	2930	9813	2963	7971	2963	4918	1122	4355	748	3995	561	3736	449	3537	374	3349	312	3035	224	X	X
S2-308	2550	12408	3979	10078	3979	6219	1332	5506	888	5051	666	4724	533	4473	444	4234	370	3837	266	X	X
S2-400	2230	16016	5251	13009	5251	8027	1582	7107	1055	6520	791	6098	633	5773	527	5466	439	X	X	X	X
S2-408	1980	19749	6557	16041	6557	9898	1912	8764	1275	8040	956	7519	765	7119	637	6740	531	X	X	X	X
S2-500	1780	24050	8135	19535	8135	12054	1902	10673	1268	9791	951	9157	761	8669	634	8208	528	X	X	X	X
S2-508	1630	28873	9885	23452	9885	14471	2120	12813	1413	11754	1060	10993	848	10408	707	X	X	X	X	X	X
S2-600	1450	31815	11460	25842	11370	15945	2274	14119	1516	12952	1137	12113	910	11468	758	X	X	X	X	X	X
S2-608	1300	33736	17883	27402	10900	16908	2180	14971	1453	13734	1090	12844	872	X	X	X	X	X	X	X	X
S2-700	1210	37484	12921	30447	11910	18787	2382	16635	1588	15259	1191	14271	953	X	X	X	X	X	X	X	X
S2-800	1040	43192	16288	35083	12490	21647	2498	19168	1665	17583	1249	X	X	X	X	X	X	X	X	X	X
S2-900	930	46826	18576	38035	13040	23469	2608	20781	1739	19062	1304	X	X	X	X	X	X	X	X	X	X
S2-1000	830	53470	21551	43431	13760	26798	2752	23729	1835	X	X	X	X	X	X	X	X	X	X	X	X
S2-1100	750	60746	24812	49341	14600	30445	2920	26958	1947	X	X	X	X	X	X	X	X	X	X	X	X
S2-1200	690	65222	27859	52977	15180	32689	3036	28945	2024	X	X	X	X	X	X	X	X	X	X	X	X

Radial Load: $Pr = A \frac{C_r}{fd} \times \left(\frac{16667}{n \times L_{10}} \right)^3$ Axial Load: $Pa = \frac{Ca \times SF}{n}$ or $.05 \times Co$, whichever is less

SF = speed factor = 1000 RPM for small bore (600 group and below)
100 RPM for large bore (608 group and above)

C_r =Dynamic Radial Load Rating
 Ca =Dynamic Axial Load Rating

Co =Static Radial Load Rating
 n =RPM

Above ratings are based upon a minimum life of 30,000 hours (L10) and utilization of EP grease, and a service factor (fd) of 1.2.

INSTALLATION

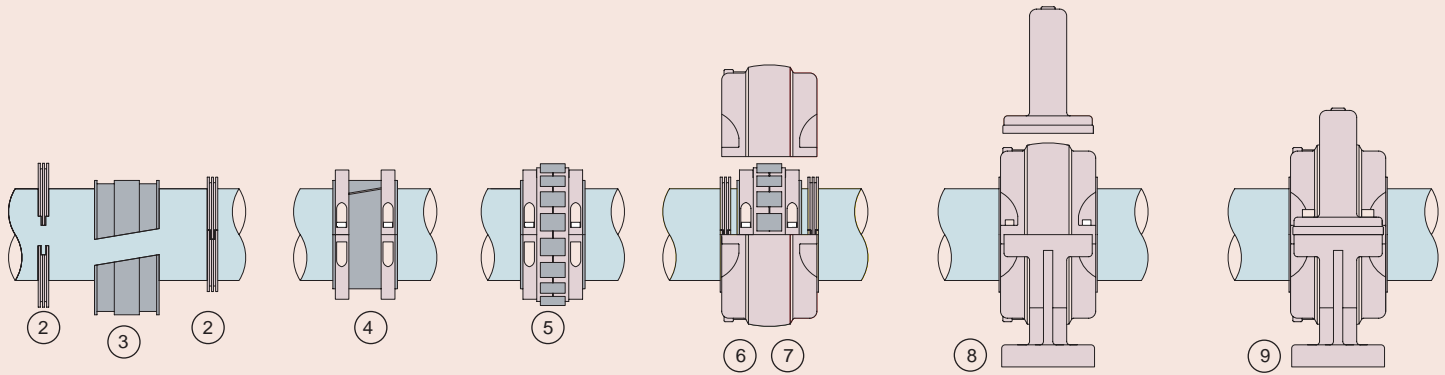

Reference Assembly Instructions below

ASSEMBLY PREPARATION

Confirm proper bearing selection has been made. Check shaft journal for roundness and size (as a general guide, $+0.000$ " to -0.005 " on diameter is acceptable). Ensure that the bearing and surrounding work areas are free of dirt and other contaminants.

ASSEMBLY (SEE DRAWINGS ABOVE)

1. Dismantle pillow block and clean bearing parts with a government-approved solvent. It is not necessary to remove outer race from cartridge.
2. Apply grease between the o-ring centers before assembling the Triple Labyrinth (TL) seals. Install the TL seals and move to the outer perimeter of the bearing journal.
3. Position inner race in proper location observing matching marks.
4. Fit the clamping collars at approximately 45 degrees from the inner race joints, insuring that there is an equal gap at the inner race joints. Tap down clamping collars with a mallet and tighten the high tensile screws equally, repeating until collars are properly seated.
5. Remove packing fasteners and ensure that provided "nyloc" screws are used to secure cage halves at joints. Coat the inner race and roller cage assembly with liberal amounts of

(DISASSEMBLY IS THE REVERSE)

6. Position seals so that they are in alignment with the grooves of the cartridge. Apply grease to the two grooves that form the outside diameter of the seals. This serves two functions: 1. To lubricate the running surfaces of the seals and cartridge. 2. To seal bearing and stop contaminants from working their way through the labyrinth and entering the bearing.
7. At this time, coat the running surface of the outer race with grease. Never assemble bearing dry, load carrying surfaces must be lubricated during assembly. Check cartridge match marks carefully, then assemble cartridge.
8. After cartridge halves are assembled, coat the spherical outside diameter of the cartridge and the bore of the housing with a graphite compound. Introduce the required amount of lubricant into the cartridge assembly.
9. Place the housing base into position, insuring that the bottom of the base is level and supported 100%. Install the housing cap. Rotate the shaft to align the cartridge assembly within the housing. Tighten the housing cap screws.

NOTE Before shafting is jacked up, all housing cap bolts should be backed off.

Warranty

Craft Bearing Company, Inc. will replace or repair any part or parts of Craft bearings that fail due to defective materials or workmanship that are returned to its factory within one year of delivery to the original purchaser. This constitutes Craft's only warranty in connection with the sale, is in lieu of all other warranties, expressed or implied, oral or written, and Craft shall have no responsibility for consequential or other damages. No employee, distributor, or agent is authorized to give any other warranty on behalf of Craft.

CRAFT
Bearing Company, Inc.

5000 Chestnut Avenue
Newport News, Virginia 23605

phone 757-247-6000
fax 757-247-6300
e-mail info@craftbearing.com
website www.craftbearing.com

Publication Data

This publication was created with an intent to provide accurate information. Craft does not assume liability for any errors or omissions. Weights are estimates. Specifications subject to change without notice.

©2005 Craft Bearing Company, Inc.
Patents Pending